

Bulletin Two

#2024BAREFOOTWORLDS

  2024BAREFOOTWORLDS.COM



2024 IWWF Open, U23 & Junior World Barefoot Water Ski Championships

From the 5th to the 12th of October 2024 in Auburndale, Florida, USA

Presented by:



Bulletin *Two*
2024BAREFOOTWORLDS.COM

Issued:
April 12th, 2024

BULLETIN TWO

Content

SECTION 1	WELCOME & LATEST UPDATES	3-4
SECTION 2	COMPETITORS	5-6
SECTION 3	ENTRY FORMS	7
SECTION 4	CURRENCY EXCHANGE	8
SECTION 5	WEBCAST	9
SECTION 6	ADDITIONAL INFORMATION	10
SECTION 7	SHOP NOW	11
SECTION 8	OFFICIAL FUNCTIONS	12
SECTION 9	SCHEDULE OF EVENTS	13-14
SECTION 10	MEET THE OFFICIALS	15
SECTION 11	ANNOUNCERS & MANAGERS	16
SECTION 12	FLY HERE	17
SECTION 13	STAY HERE	18
SECTION 14	CEREMONIES	19
SECTION 15	MEET OUR SPONSORS	20
SECTION 16	SIGN UP LINKS	21
SECTION 17	CONTACT US	22

Welcome to the Water Ski Capital of the World!

On behalf of Visit Central Florida, I look forward to welcoming you to the undisputed Water Ski Capital of the World.

The history of water skiing is intertwined with the history of the Central Florida. While others promoted the sport, water skiing only reached the masses thanks to Dick Pope Sr., who saw the colorful and athletic sport as a perfect promotional vehicle. Utilizing then cutting-edge technology - color film - Pope single handedly changed the image of not just Central Florida but of the state itself, while creating the Sunshine State's first theme park, Cypress Gardens.

As the park's notoriety grew, so did the profile of water skiing. Soon, athletes from around the world came to Cypress Gardens to ply their trade on the greatest stage possible. This influx of talent led to greater competition and higher stakes. The end result is that more records have been broken, inventions created and innovations birthed (including Barefoot Water Skiing) in the sport of water skiing on Polk County waters than anywhere else in the world.

While Cypress Gardens in its original form may have changed, it is far from

forgotten. The botanical gardens are still part of the LEGOLAND Florida Resort, as is the water ski show. Our theme park tradition recently grew with the opening of the Peppa Pig Theme Park, the first park in the world dedicated to the preschooler. The Cypress Gardens Water Ski Team, a mix of theme park veterans and amateur skiers, remains an integral part of our community. Their shows are attended by adoring fans who make the pilgrimage to our water ski mecca from around the nation, helping feed our thriving hospitality industry. The lake they perform on, Lake Silver, was also host to the 2022 Show Ski World Championships.

We hope you will enjoy your October visit to The Water Ski Capital of the World. We are more than honored to be part of it. We hope that your stay here not only inspires your return but inspires others to get involved in the best sport on water, water skiing.

As you can see, we have accomplished so much over the first 100+ years of the sport. We are actively planning for the World's to be a corner stone of the next 100 years of history. See you soon!

NEAL DUNCAN

Visit
Central Florida 

Latest Updates

NEW LAKE IS COMPLETE

Spring already? Time is flying by. Slow down and come check out Championship Lake in Auburndale! Many thanks to the City of Auburndale Parks and Recreation along with Visit Central Florida on the new venue for the 2024 IWWF Open, U23 and Junior World Barefoot Water Ski Championships!



CLOSING CEREMONY BANQUET TO INCLUDE HOF

A couple individuals will be honored as part of the IWWF International Hall of Fame! Congrats to athlete David Small and official Brian Price who will be honored during closing ceremony banquet on Saturday, October 12th.



NEW! TRAVEL GUIDE

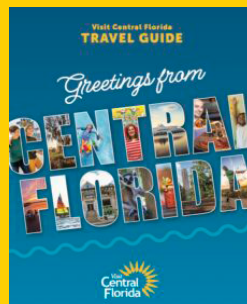

Visit Central Florida's new Travel Guide is a comprehensive guide full of valuable resources about the area's attractions, hotels and vacation rental homes, restaurants, boutique shops and more.

We'll Mail You a Travel Guide - For Free!

Yes, we will send you a hard copy of our Travel Guide for free! Dog-ear pages, make notes and bring it with you on your trip.

<https://visitcentralflorida.org/travel-guide/>

WEBSITE & SOCIAL MEDIA

OFFICIAL WEBSITE: 2024BarefootWorlds.com

FACEBOOK: Facebook.com/2024BarefootWorlds

INSTAGRAM: @2024BarefootWorldsssss

HASHTAGS: #2024BarefootWorlds #VisitCentralFL

COMPETITORS

UPDATES

CHAMPIONSHIP LAKE, AUBURNDALE

THE 2024 IWWF OPEN, U23 AND JUNIOR BAREFOOT WORLD CHAMPIONSHIPS WILL BE THE LARGEST TOURNAMENT TO DATE ON THE NEWLY BUILT CHAMPIONSHIP LAKE IN AUBURNDALE, FLORIDA!

Championship Lake is a freshwater lake located within Lake Myrtle Sports Park. The lake is 2300ft long (701m), 300ft wide (91m) with a depth of 8-12ft (2-3.5m) in the middle. It is a private lake that stretches north to south with one point of entry at a private boat ramp.

The complete document, 2024 IWWF Barefoot Rulebook ,that includes specific details related to the Competition Site can be found on the event website. Please visit the website to view our Google Earth link that displays the site layout.

<https://2024BarefootWorlds.com/The-Site/>

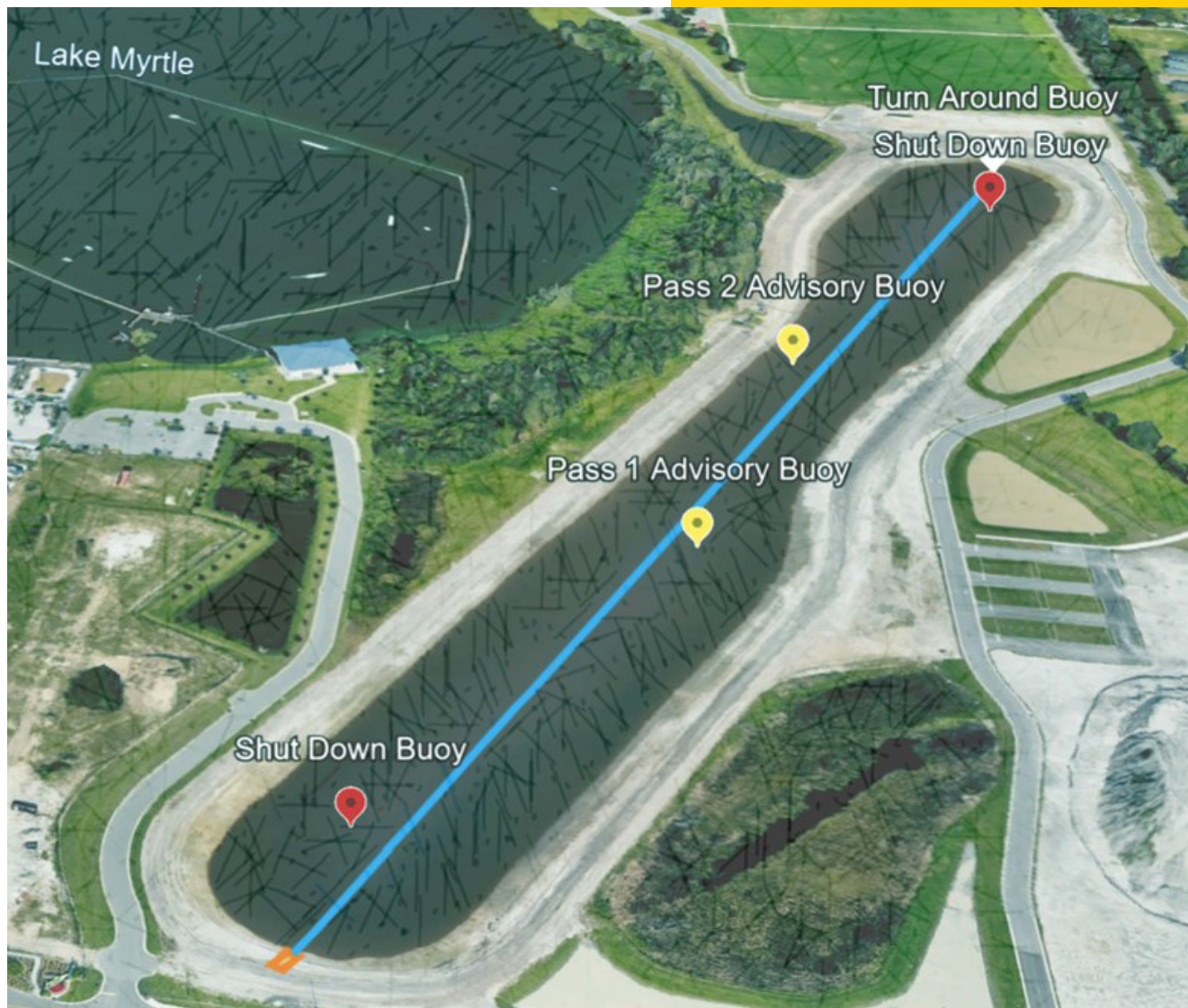

Jump Course Dimensions 1601

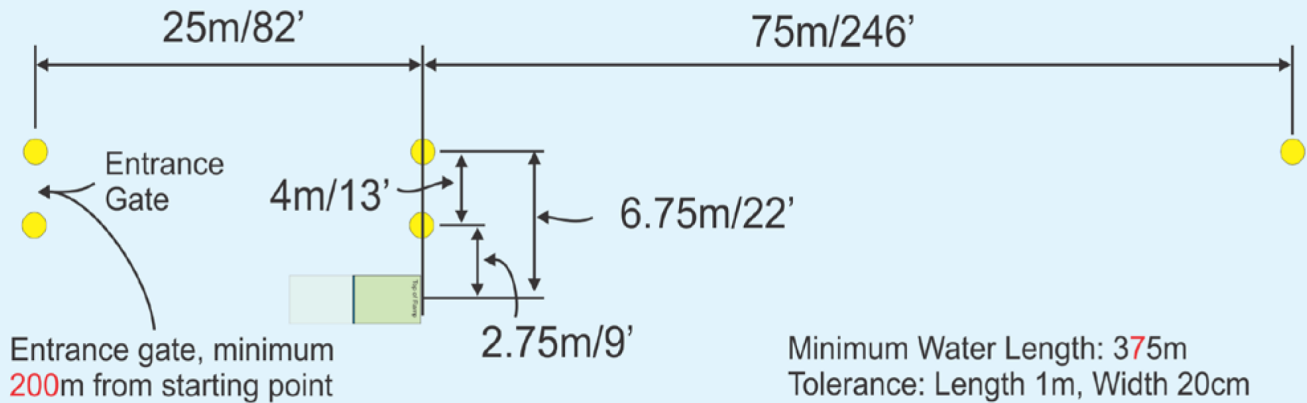

EVENT PHOTOS

Teams and Individuals will have opportunity to view event photos from our official event photographer, Greg Adams, on our official Facebook Page. Digital photos will be available at our designated Media Center on site.



SERVICES

Visit Central Florida can assist with preparing your Central Florida Vacation! Looking for fun activities and local events in the area? Do you need attraction tickets for theme parks and more? We have it! Get in touch with Shauna@vcfsports.com for assistance.



PRACTICE

Unofficial Training at Championship Lake: 9/23 - 10/1

Contact: jmcscornish@gmail.com

**Official Familiarization
Championship Lake: 10/3 - 10/5
Secondary Lake: 10/5**



SITE ENTRY

Entry to Lake Myrtle Sports Park is free. Food and drinks will be available for purchase on event days for spectators with local food trucks. Alcohol is not permitted in the park.



ANTI-DOPING

Doping controls will be conducted during the competition. By entering the event, all athletes agree to be subject to doping control. Visit <https://IWWF.Sport/Athletes/Anti-Doping/>



TEAM TENTS

Tents will be on site for teams and individuals. UV rays are most intense between 10am and 4pm (even on cloudy days). Cover up with light-weight clothing, a hat, use sunscreen and lip balm containing at least an SPF of 15.

7 ENTRY FORMS

SIGN UP TODAY!

Athletes must be entered by their respective Federations no later than **September 2**, which is 4 weeks prior to the event. Any Federation not meeting this deadline will not be allowed to compete until the Federation pays to the WBC a fine of \$20 (USD) per skier per day for each skier not entered by the deadline, until such skier is entered. Federations must enter their athletes electronically via the EMS system (<https://ems.iwwf.sport/>). Payment should be made at time of entry via Paypal or credit card. Detailed instructions as to what information will be needed and how to enter using the EMS system will be sent separately via email to Federation Representatives.

TEAMS

Not later than 4 weeks before the scheduled start of the Championship, each Federation intending to enter a team shall certify the names of the skiers that will be skiing team member and the events each will enter in the EMS System. The names of up to two reserves for each team shall also be submitted as well. A Webcast Athlete Bio form and Payment button can be found in the EMS System as well.

INDIVIDUALS

Not later than 4 weeks before the scheduled start of the tournament, each Federation shall submit the names of any of its qualified independent skiers it wishes to enter, and the event or events they will enter in the EMS System. A Webcast Athlete Bio form and Payment button can be found in the EMS System as well.

FINAL LIST

Not later than 72 hours before the start of competition a Final Team List must be submitted in writing to the Chairman of the WBC and the Chief Judge. This list, which shall be comprised solely of skiers named in the EMS System, shall clearly indicate which are Team Skiers and which are Reserve Skiers as well as their relevant divisions. Failure to do so will disqualify the team from the team event.

PASSPORT REMINDER

Passports must be valid for six months beyond the date the traveler will exit the United States. Please visit our website with updated travel information for countries requiring a Visa Waiver Program (VWP), (ESTA) and B2 Visa.

ATHLETE INFORMATION

All competitive teams and individual competitors will have a dedicated country page for photos on the event website. A team bio /athlete information webcast form will be included in our Team Manager Welcome Packet.

CERTIFY ENTRIES

Chairman of the WBC: worldbarefoot@gmail.com
Chief Scorer, Mark Shank: markshank34@gmail.com
Rulth Molford, Registrar: struth81@hotmail.com
LOC Chair, John Cornish: jmccornish@gmail.com

CURRENCY EXCHANGE

All currency exchange should take place at the International Airport you arrive at or depart from. Smaller Regional airports will not be able to facilitate a transfer. Local Banks will have limited facilities to exchange moneys. ***Please Note: Camp Margaritaville is a CASHLESS FACILITY - Major Credit Cards accepted only.**



WORLD TEAM SKIERS

\$ 425 USD

INCLUDES: Transportation to secondary lake and Opening Ceremony. Admission to all receptions and banquets.

WORLD INDEPENDENT SKIERS

INCLUDES: Transportation to secondary lake and Opening Ceremony. Admission to all receptions and banquets.

1 Event \$325 USD
2 Events \$375 USD
3 Events \$425 USD

DUAL EVENT

Entry Fee for the second entry.

1 Event \$225 USD
2 Events \$275 USD
3 Events \$325 USD

LATE FEE

\$20 USD

Any Federation not meeting the requirements won't be allowed to compete until the Federation pays to the WBC a fine of \$20 (USD) per skier per day after the four-week deadline, for each skier not officially entered. Late Fees payments will be collected at check in (cash or card).

ALL ENTRY FEES MUST BE PAID IN US\$ ONLY.

PAYMENT INFORMATION FOR BANK WIRE TRANSFERS

ADDRESS:

BANK FIRST, N.A.
 402 N 8th Street
 Manitowoc, WI 54221-0010



BankFirst

BANK INFO:

Beneficiary Bank: Bank First, N.A.
Bank Address: 402 N. 8th Street, Manitowoc, WI 54220 USA
BIC/SWIFT: FRNIUS44
ABA: 075901134
Beneficiary Name: USA Water Ski & Wake Sports
Beneficiary Address: 2701 Lake Myrtle Park Rd. Auburndale, FL 33823 USA
Account Number: Contact RyanGilman@gmail.com
Reference: 2024 IWWF Barefoot Worlds Entry Fee

WEBCAST

TWO WEBCAST PRODUCTIONS WILL BE LINKED TO OUR EVENT WEBSITE. ONE PRODUCED BY JOHN GARRITY AND THE OTHER (FINALS DAYS ONLY) PRODUCED BY ALL SPORT WEB PRODUCTIONS.

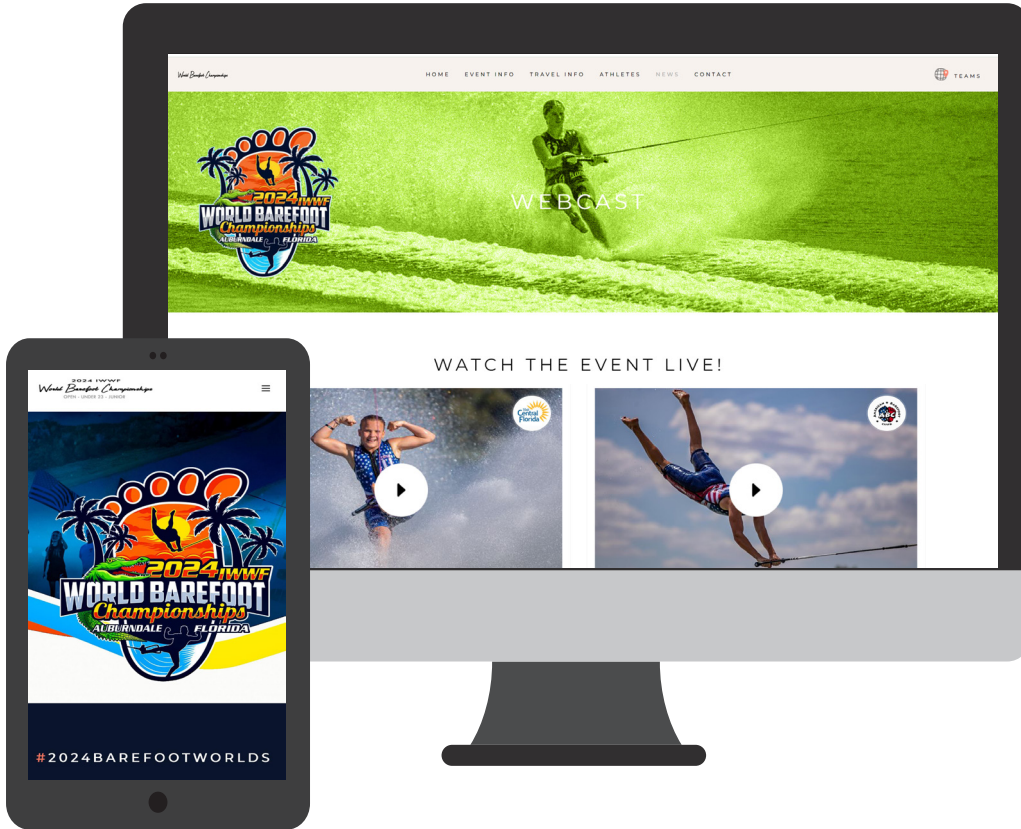

We would like to highlight your Team's Story on the webcast prior to your performance at the event.

▼ **VIDEO CLIPS**

This summer we will be contacting each team to gather short video clips that describe the following: team practice location, team training, highlight team sponsors and your journey to worlds. We would like to share your team and your story.

▼ **WEBSITE INFORMATION**

Each team has their own page on the event website that provide fans your information and history. More requested information will be found in our event welcome packet for team managers. We plan to link all team socials, sponsors, videos and any information your team would like to share on the official event website.

TELLING YOUR STORY

-  **10/3 - 10/5
3 DAY EVENT WEBCAST**
-  **ATHLETE AND
TEAM STORIES**
-  **CENTRAL FLORIDA
BAREFOOT HISTORY**
-  **SPONSORS AND
MORE**



ADDITIONAL INFORMATION

TRAVEL AND MORE

01 TRAVEL INSURANCE

The IWWF Bye-Law 16.1 states: It is the responsibility of each Federation when entering competitors for a World Titled Event to ensure that its competitors are adequately insured for personal accident, permanent disabilities, death and medical expenses.

02 INTERNATIONAL TRAVEL

Make sure you have the right documentation before you travel internationally. If your country is part of the 40 countries that participate in the Visa Waiver Program, you are allowed to travel to the United States for business or tourism for stays of up to 90 days without a visa. If your country is not part of the 40 countries listed, then you will need to fill out an Electronic System for Travel Authorization (ESTA) form before travelling internationally. More information and links can be found on our event website. <https://2024barefootworlds.com/travel-requirements/> **PASSPORTS MUST BE VALID 6 MONTHS BEYOND THE DATE THE TRAVELER WILL EXIT THE UNITED STATES.**

03 EMERGENCY PERSONNEL

The event or LOC will provide emergency personnel certified in water rescue, recovery and transport during practice and competition. We will have certified paramedic and USA Water Ski and Wake Sports certified water safety personnel that will be available during practice and competition. Each team will be expected to receive and adhere to safety regulations set forth by the IWWF Safety Rules and Chief Safety Director.

04 IWWF SAFE SPORT POLICY & SAFEGUARDING REGULATIONS

The IWWF takes athlete safeguarding extremely seriously and is committed to ensuring that everyone who attends the tournament, whether athletes, officials or volunteers are able to operate in a safe environment, free from abuse and the risk of harm. It is a condition of participation that all attendees familiarise themselves and comply with the IWWF Safeguarding Regulations which are available at <https://iwwf.sport/safe-sport/>

05 USA WATER SKI & WAKE SPORTS INSURANCE

All athletes are required to sign up as members of USA Water Ski & Wake Sports for insurance purposes before they are permitted to compete in the 2024 IWWF Open, U23 and Junior World Barefoot Water Ski Championships. There will be NO cost for the membership. A link to sign up for the membership will be provided and Federations should ensure their athletes are signed up before official familiarisation begins.



SHOP NOW

BAREFOOT WORLDS TOURNAMENT APPAREL

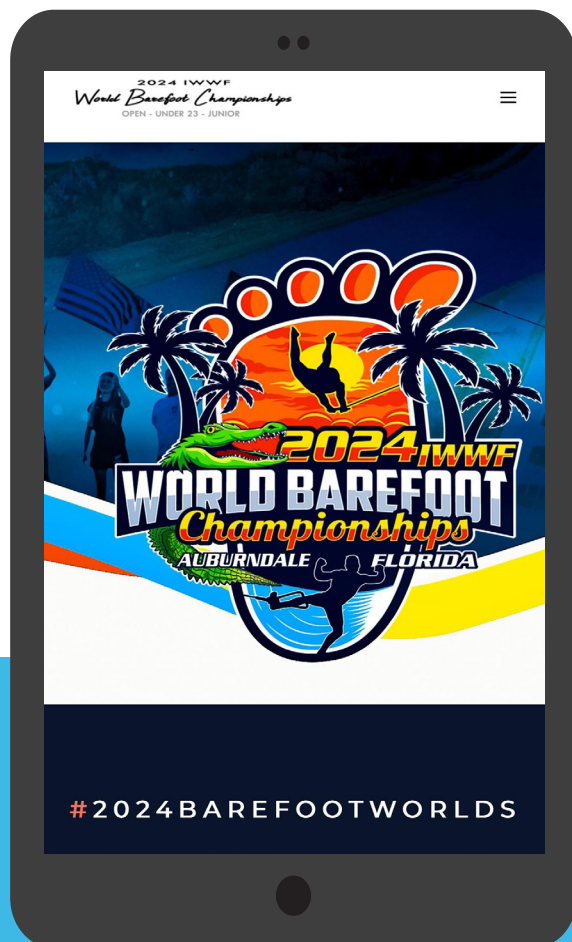

2024 BAREFOOT WORLDS ONLINE STORE GOING LIVE SOON!

Be sure to check out the new World Barefoot Water Ski Championships Store to find apparel, including t-shirts, sweatshirts, hats, along with other merchandise and gear.

International fans will have the opportunity to order items online and pick up at our Welcome Information Center (official check in location for teams, individuals and officials).

Group, LLC
Overwear Apparel



CAMP MARGARITAVILLE STORE

Snacks, drinks, camp supplies, Florida merchandise and many souvenirs! Check out all they have in store. Open daily at 8:00 am **Please Note: Camp Margaritaville is a CASHLESS FACILITY - Major Credit Cards accepted only.**



ON SITE EVENT MERCHANDISE

The ABC will have an Official Event Merchandiser on site at the 2024 IWWF Open, U23 and Junior World Barefoot Water Ski Championships.



OFFICIAL FUNCTIONS

JOIN IN ON THE FUN!



EVENT
TICKETS
FOUND
ONLINE

5TH

OPENING CEREMONY - LEGOLAND FLORIDA

The Opening Ceremony will include a parade of athletes, welcome speeches, live music and skiing demonstrations from the Cypress Gardens Water Ski Team. VIP Reception for officials and dignitaries will be in the Garden Center before the event. Enjoy this warm welcoming event from the Water Ski Capital of the World!

Location: Lake Silver, Winter Haven

6TH

EVENING PAVILLION SOCIAL EVENTS

OCTOBER 6: Ryan Gilman & Scott Gray performance with Brad Henderson book signing.

OCTOBER 7: DJ Davie

OCTOBER 8: Trivia Night

OCTOBER 9: Karaoke

OCTOBER 11: Cornhole Tourney

Location: Camp Margaritaville, Auburndale

10TH

NIGHT WITH THE LEGENDS

Join us at Camp Margaritaville's Pavilion by the lake for a Night with the Legends! Come meet and mingle with some of our sports best! Entry is free and food/beverage available for purchase.

Location: Camp Margaritaville, Auburndale

12TH

CLOSING CEREMONY

The Award Ceremony at the lake will follow and the Closing Ceremony Banquet will conclude the event. Join us as we induct a new IWWF Hall of Fame member!

Location: Camp Margaritaville, Auburndale

Visit
Central
Florida

COME SKI OUR
WATERS & BE PART
OF OUR HISTORY!



SCHEDULE OF EVENTS

AS OF 4/30/24

THURSDAY 10/3

OFFICIAL PRACTICE DAY 1 ★

FRIDAY 10/4

OFFICIAL PRACTICE DAY 2 ★

SATURDAY 10/5

OFFICIAL PRACTICE DAY 3 ★

WORLD BAREFOOT
COUNCIL MEETING 

OFFICIALS CLINIC 

OPENING CEREMONY 

SUNDAY 10/6

MONDAY 10/7

TUESDAY 10/8

LAKE 1

LAKE 1

LAKE 2

LAKE 1

LAKE 2

JR GIRLS: TRICKS R1

JR BOYS: TRICKS R1

U23 WOMEN: JUMP R1

U23 WOMEN: SLALOM R1

MENS: JUMP R1

JR BOYS: SLALOM R1

MENS: SLALOM R1

WOMENS: JUMP R1

WOMENS: TRICKS R1

U23 MENS: JUMP R1

U23 MENS: TRICKS R1

U23 MENS: SLALOM R1

JR GIRLS: JUMP R1

JR GIRLS: SLALOM R1

U23 WOMEN: TRICKS R1

WOMENS: SLALOM R1

JR BOYS: JUMP R1

The official running order for the competition will be posted online and our social channels. Tickets and additional information for official functions can be found on our event website.

WEDNESDAY 10/9

THURSDAY 10/10

FRIDAY 10/11

SATURDAY 10/12

LAKE 1

LAKE 1

LAKE 1

LAKE 1

MENS: TRICKS R1

U23 WOMEN: TRICKS FINAL

U23 MENS: JUMP FINAL

WOMENS: SLALOM FINAL

U23 MENS: SLALOM FINAL

JR GIRLS: SLALOM FINAL

U23 WOMEN: JUMP FINAL

MENS: SLALOM FINAL

JR GIRLS: JUMP FINAL

JR BOYS: SLALOM FINAL

JR BOYS: TRICKS FINAL

WOMENS: TRICKS FINAL

JR BOYS: JUMP FINAL

WOMENS: TRICKS R2

JR GIRLS: TRICKS FINAL

MENS: TRICKS FINAL

U23 WOMEN: SLALOM FINAL

MENS: TRICKS R2

U23 MENS: TRICKS FINAL

WOMENS: JUMP FINAL

WOMENS: SLALOM R2

WOMENS: JUMP R2

MENS: JUMP R2

MENS: JUMP FINAL

MENS: SLALOM R2

NIGHT WITH THE LEGENDS EVENT



CLOSING AWARDS BANQUET



SUNDAY 10/13

WRAP UP REVIEW MEETING

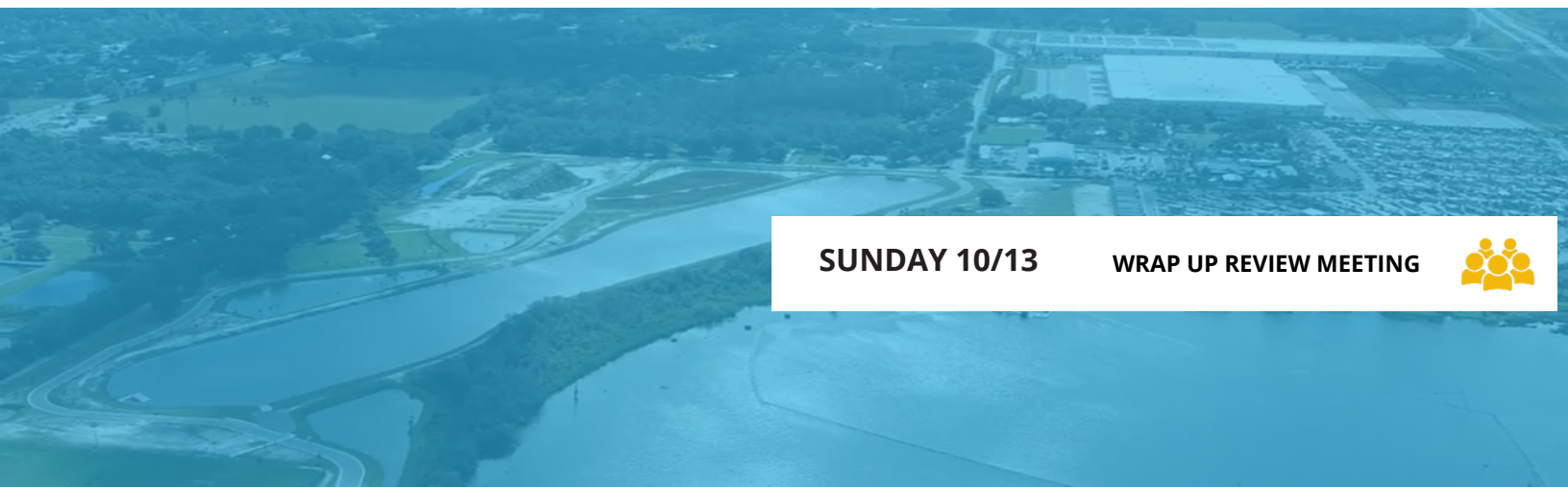

MEET THE OFFICIALS

ROBBIE GROEN (NZL)



Tournament Director

LYN BLAAUW (AUS)



Chief Judge

MARK SHANK (USA)

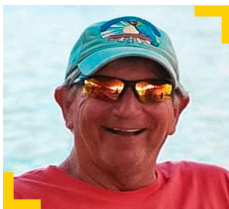

Chief Scorer

RICHARD GRAY (CAN)



Chief Driver

H FRY (USA)



Chief Safety

ANDREA FORMELLA (USA)



Assistant Chief Judge

RUTH MOLFORD (AUS)



Assistant Chief Scorer

CHUCK BENDER (USA)



Assistant Safety Director

PAUL TURNER (GBR)



Homologator

JODIE KELLY (NZL)



Scorer

GARY KEEN (AUS)



Driver

RON MEEKS (USA)



Driver

DANNY GATHERCOLE (AUS)



Driver

JIM FORSTER (USA)



Reserve Driver

GEOFF RIESEN (AUS)



Reserve Driver

ANDY HARRIS (GBR)



Judge

LUDO VRANCX (BEL)



Judge

JOE KNAPP (USA)



Judge

LEE STONE (USA)



Judge

GERDY BONGAERTS (BEL)



Judge

JODIE DUNCAN (AUS)



Judge

PETER FRANKS (AUS)



Judge

MIKE MOLEPSKE (USA)



Judge

STUART BALL (AUS)



Judge



ANNOUNCERS & MANAGERS

The American Barefoot Club has selected the official Master of Ceremonies for the 2024 IWWF Open, U23 and Junior World Barefoot Water Ski Championships.

Swampy Bouchard of Winter Haven, Florida has been a coach/manager of many barefoot water skiers and World Championship barefoot teams.



ADDITIONAL ANNOUNCERS

LOGAN WALTER
PAUL STOKES
KEITH ST. ONGE
JOHN CORNISH
WILLIAM FARRELL

SOCIAL MEDIA & WEBSITE MANAGERS

CHRISTINA NADALIN - Social Media

Marketing & Events Coordinator at World Barefoot Center
 Christina.Nadalin@hotmail.com

MEGAN ADAMS - Social Media

Marketing & Events Coordinator at World Barefoot Center
 girlfooter@gmail.com

SHAUNA PASANEN -Website

Creative Coordinator at Visit Central Florida Sports
 Shauna@VCFsports.com

MEDIA MANAGER

Betsy Gilman

Writer, Content Producer, Digital Nomad at
Just Add Water Media

Betsy.anderson.gilman@gmail.com

SOCIAL MEDIA & MARKETING
 COMMITTEE



Betsy Gilman

FLY HERE. STAY HERE

OFFICIAL AIRLINES & ACCOMODATIONS

DELTA

Official Air Line of the 2024 IWWF Open, U23 & Junior World Barefoot Water Ski Championships

Now offering discounts on Delta flights to Orlando (MCO) or Tampa (TPA) for the event with travel from 9/18/24 through 10/19/24!

Book with Meeting Event ID Code: NM39L

Visit Central Florida
WATER SKIING 100 YEAR ANNIVERSARY
USA WATER SKI & WAKE SPORTS
AMERICAN BAREFOOT CLUB

2024 IWWF World Barefoot Championships
ALBUARDALE FLORIDA

“THE WORLD’S MOST TRUSTED AIRLINE.” DELTA IS OFFICIAL AIR LINE OF THE 2022 IWWF WORLD WATER SKI SHOW TOURNAMENT.

ORLANDO INTERNATIONAL AIRPORT TERMINAL C

An ode to the region, the new terminal is an architectural depiction of everything that attracts tourists to central Florida. The terminal's design captures the elements of water, foliage and sky with expansive glass skylights, terrazzo artist interpretations of natural springs and incredibly life-like artificial palm and bald cypress trees. The design is highlighted by massive electronic media entertainment features that display iconic scenes of central Florida fauna, flora and attractions that more than 50 million guests a year come to Orlando to see.

Terminal C not only provides a positive and welcoming experience, but also maximizes the safety, security and efficiency of the travel process. The project incorporates many industry firsts, such as:

- 100% total virtual ramp control for airline ground operations
- 100% automated public screening lanes at the TSA checkpoint
- 100% facial recognition “e-gates” for international arrival and departures

- “Bags First” design in Customs and Border Protections Arrivals
- 100% trackable baggage handling system
- Fully integrated, multimodal airport terminal with direct high-speed rail connectivity
- A design targeting LEED®v4 campus-wide certification



ACCOMMODATIONS

THE SOUTHERN REGION BAREFOOT CLUB HAS BEEN OFFICIALLY ENTRUSTED WITH THE MANAGEMENT OF HOTEL ACCOMMODATIONS OF THE COMPETITORS, OFFICIALS AND DIGNITARIES.

PLEASE NOTE: Camp Margaritaville is a CASHLESS FACILITY - Major Credit Cards accepted only.



SPECTATORS

Camp Margaritaville RV Resort

Address: 361 Denton Ave, Auburndale, FL 33823

Camp Margaritaville Auburndale is Florida's newest RV and cabin resort boasting scenic Lake Myrtle views and the largest RV sites to accommodate your home away from home. Located in Auburndale off the Polk Parkway, you will be at the center of all Florida's most sought after attractions. They offer oversized roadways and pull-through and back-in sites, so your big rig is welcome! From all your necessities to a calendar filled with resort activities, you'll have everything you need to maximize your Florida vacation right on site. They also offer beautifully designed cabins as a better than hotel alternative to keep your family of up to 6 people* in a 5-star hotel resort style. Long-term stay options available. (*Some models sleep up to 4). **PLEASE CALL THE FRONT DESK TO RESERVE FROM OUR OFFICIAL ROOM BLOCK. (863) 455-7335**



ADDITIONAL AREA HOTELS

Near Championship Lake, Auburndale

Download our Visit Central Florida App. Be sure to sign up for our Polk Savings Pass on our App for Central Florida Discounts!

Where to stay in Polk County, including resorts, hotels, motels, cabins, RV sites, campsites and more can be found on VisitCentralFlorida.org

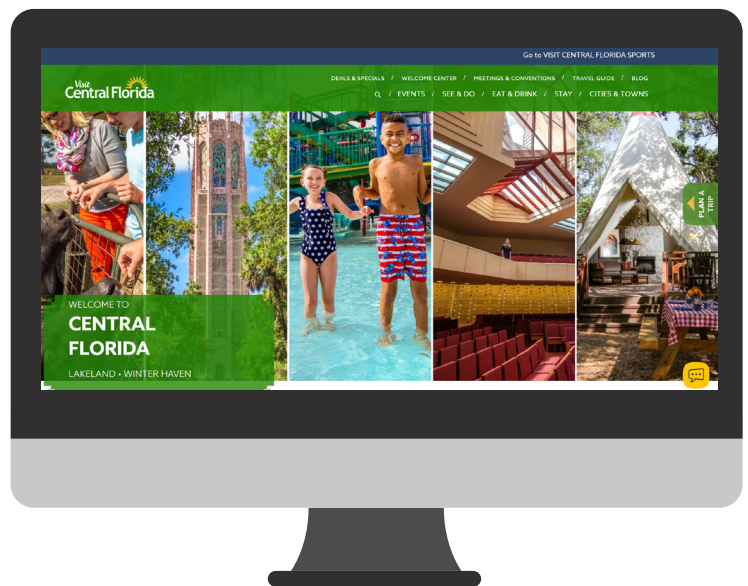
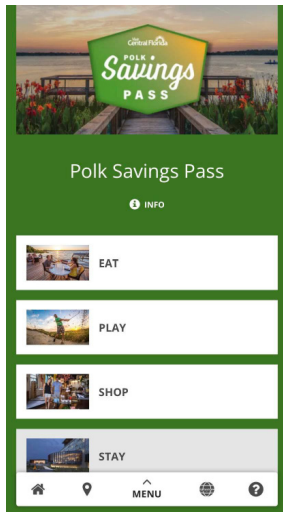
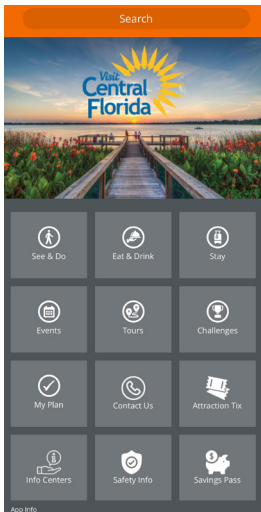

OPENING CEREMONY



SCHEDULE (TENTATIVE)

4:00 - 5:00	VIP RECEPTION
4:30 - 5:30	ATHLETE LINE UP
5:30	OPENING CEREMONY START
6:30	OPENING CEREMONY END

CLOSING CEREMONY

Tickets will be available soon for purchase on the event website. Dinner tickets are \$110USD.

Menu for the Evening: Penne marinara
grilled chicken with lemon and capers.
Oven roasted salmon with dill butter,
sauteed green beans, scallop potatoes
fresh greens salad, fresh berries with
fruit and bourbon pecan pie.



SPONSORS

MEET SOME OF OUR PARTNERS!

		
		
		
Jack and Colleen Schumann Jack and Sarah VandeVisse	Ed & Lisa Talerico Julie McCauley Glenn Kinnear	SKG Containment Scott Dunn Bethel Park PA



Sanger Boats are the official towboats for the 2024 IWWF Open, U23 and Junior World Barefoot Water Ski Championships.

SIGN UP LINKS

BE A PART OF OUR EVENT!

EVENT VOLUNTEER

Contact: Betsy Gilman
Betsybarefoots@aol.com

EVENT VENDOR

<https://2024barefootworlds.com/vendor-area/>



CONTACT US FOR SPONSORSHIP OPPORTUNITIES

It is important to be an active partner in the 2024 IWWF Open, U23 & Junior World Barefoot Water Ski Championships. We aim to provide unique touchpoints and experiences during the event.



Eric Croyer
SPONSORSHIP SALES
Email: ericcroyer@gmail.com

HELPFUL DEADLINES TO REMEMBER

**OFFICIAL/DIGNITARY
INTENT TO ATTEND**

APRIL 30TH

**TEAM/ INDIVIDUAL
INTENT TO ENTER**

JUNE 10TH

**ENTRY FORM (EMS)
AND ENTRY FEES**

SEPT 2ND

CONTACT US

SEE Y'ALL SOON!

CONTACT US

Visit Central Florida

2701 Lake Myrtle Park Rd.

Auburndale, FL 33823

Phone: (863) 551-4750

Website: VisitCentralFlorida.org

SANCTIONING BODY IWWF

President - Jose Antonio Perez Priego

Executive Director- Paul Fong

Chairman, IWWF Barefoot Council - Geoff Blaauw

Chairman, LOC - John Cornish